

ECOJET



GENERAL DATA

Applications

Self-priming centrifugal pump with excellent suction capacity even when there are air bubbles and small particles of sand in the water.

Used especially for supplying water to domestic installations. Ideal for use in small scale agriculture and gardening services wherever self-priming operation is necessary.

Constructional features of the pump

Technopolymer pump body and motor support.

Technopolymer impeller, diffuser, venturi and nozzle.

Carbon/ceramic mechanical seal.

Constructional features of the motor

Induction motor, closed and cooled with external ventilation.

Rotor mounted on oversized greased sealed-for-life ball bearings to ensure silent running and a long life.

Built-in thermal and current overload protection on ECOJET 110

Built-in thermal and resettable overload protection on ECOJET 120/130

Capacitor permanently in circuit.

Manufactured according to UL 778 -2010 & CSA 108-1

Motor protection: NEMA3

Terminal Box protection: NEMA3

Insulation class: F

Standard voltage: 115v 60Hz

TECHNICAL DATA

MATERIALS

N°	PARTS*	MATERIALS
1	PUMP BODY	TECHNOPOLYMER
2	IMPELLER	TECHNOPOLYMER
3	ROTOR SHAFT	AISI 416 STAINLESS STEEL UNI EN 10088-1 X12CrS13
4	MECHANICAL SEAL	CARBON - CERAMIC
5	'O' RING	NBR RUBBER
6	NOZZLE-VENTURI	TECHNOPOLYMER
7	DIFFUSER	TECHNOPOLYMER

* In contact with liquid

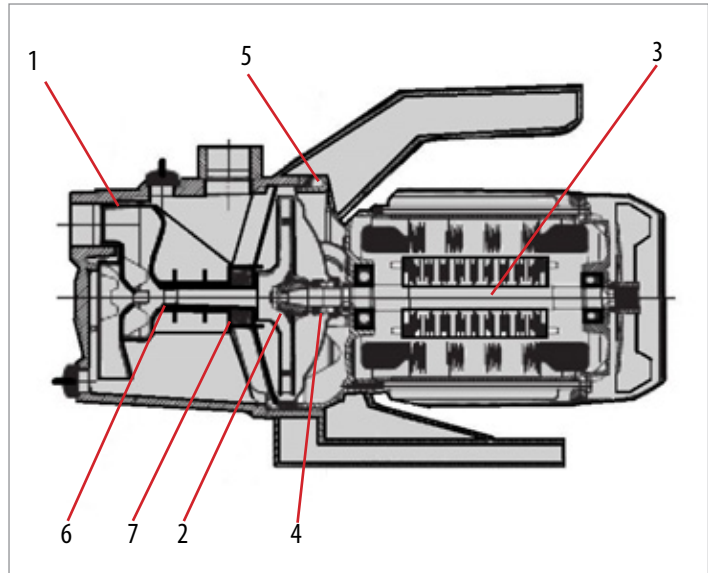

Operating Range:	From 1 to 21gpm with a head up to 164ft (71 psi)
Liquid quality requirements:	clean, free from solids or abrasive substances, non viscous, non aggressive, non crystallized, chemically neutral, close to the characteristics of water
Liquid temperature Range:	From 32°F to 95°F
Maximum Suction depth:	26 ft
Maximum ambient temp.	104°F
Maximum operating pressure	87 psi
Installation:	fixed or portable in a horizontal position
Special version on request	other voltages and/or frequencies

ECOJET R 90

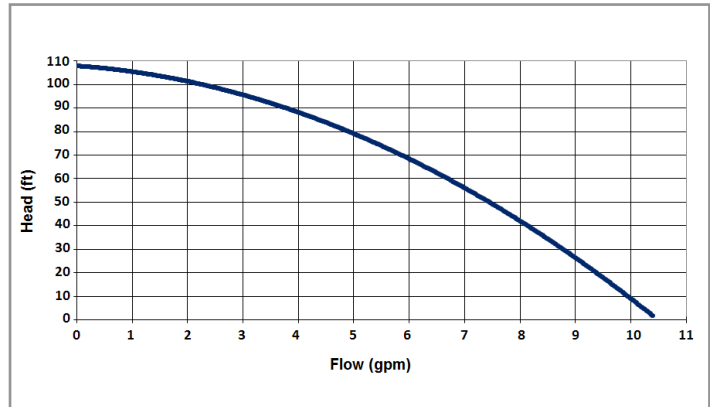
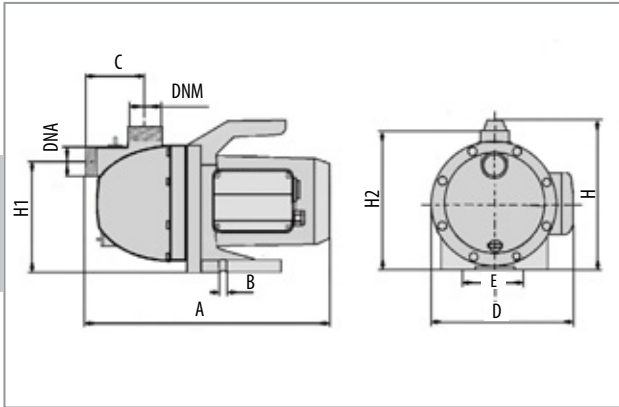

MODEL	A	B	C	D	E	H	H1	H2	DNA	DNM	Weight
ECOJET R 90	14 1/4"	3/8"	3 5/8"	8 1/4"	5 1/2"	8 3/4"	6"	8"	1" NPT	1" NPT	13.5 lbs

MODEL	ELECTRICAL DATA				HYDRAULIC DATA		
	Voltage 60Hz	P1		In A	MAX Flow	Max Head	Max Pressure
	kW	Hp					
ECOJET R 90	115v	600	1/3	6.3	10.4 gpm	108 ft	47 psi

ECOJET 110

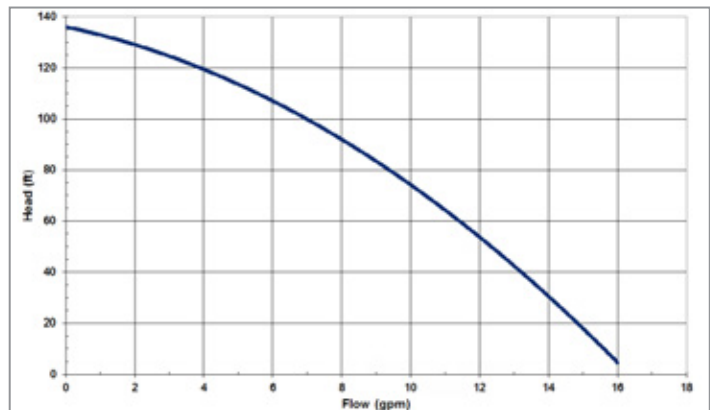
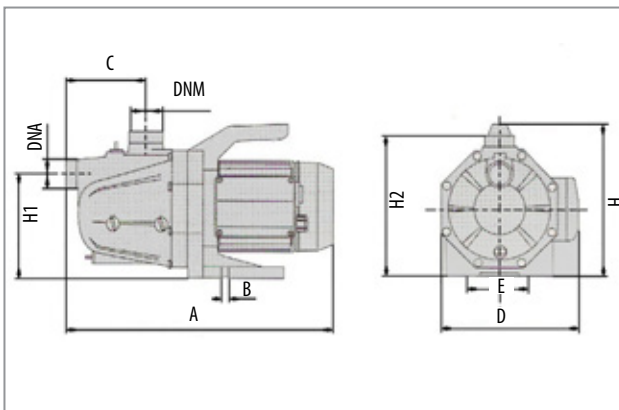

MODEL	A	B	C	D	E	H	H1	H2	DNA	DNM	Weight
ECOJET 110	15 3/4"	3/8"	4 5/8"	8 3/4"	5 3/4"	9 1/2"	6 1/2"	9 1/8"	1" NPT	1" NPT	19.2 lbs

MODEL	ELECTRICAL DATA				HYDRAULIC DATA		
	Voltage 60Hz	P1		In A	MAX Flow	Max Head	Max Pressure
	kW	Hp					
ECOJET 110	115v	800	1/2	7.8	16 gpm	138 ft	60 psi

ECOJET 120

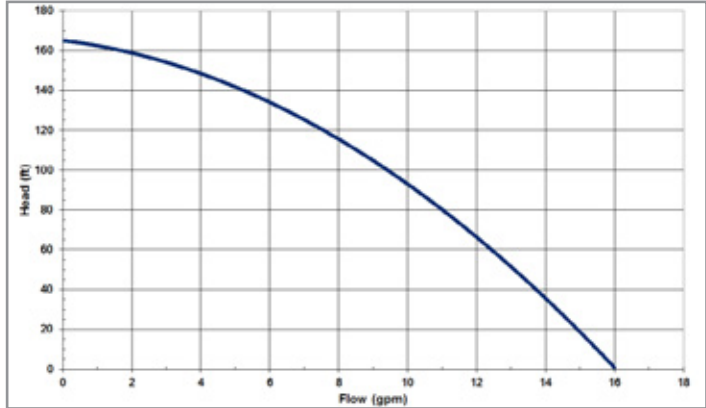
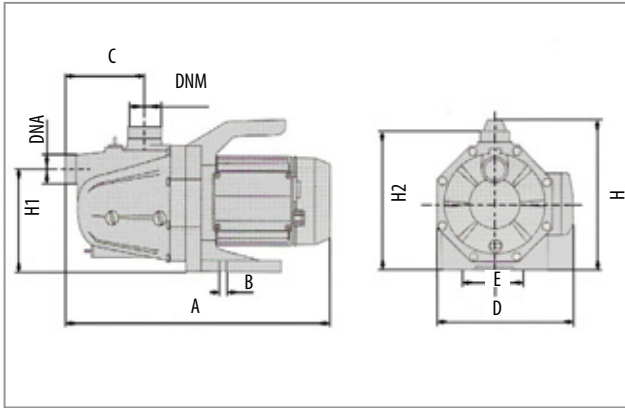

MODEL	A	B	C	D	E	H	H1	H2	DNA	DNM	Weight
ECOJET 120	15 3/4"	3/8"	4 5/8"	8 3/4"	5 3/4"	9 1/2"	6 1/2"	9 1/8"	1" NPT	1" NPT	20.7 lbs

MODEL	ELECTRICAL DATA				HYDRAULIC DATA		
	Voltage 60Hz	P1		In A	MAX Flow	Max Head	Max Pressure
		kW	Hp				
ECOJET 120	115v	1000	3/4	9.8	16 gpm	164 ft	71 psi

ECOJET 130

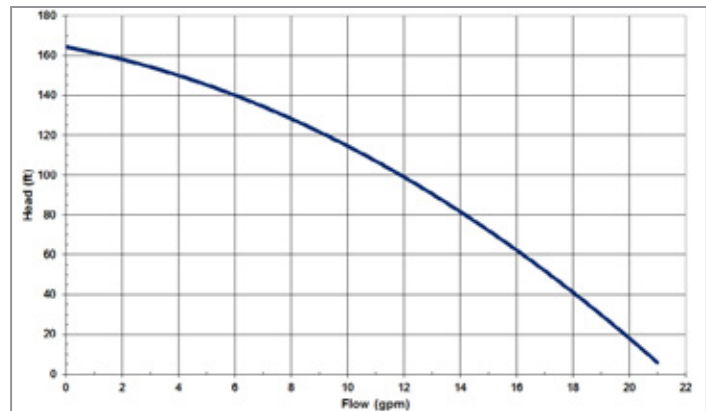
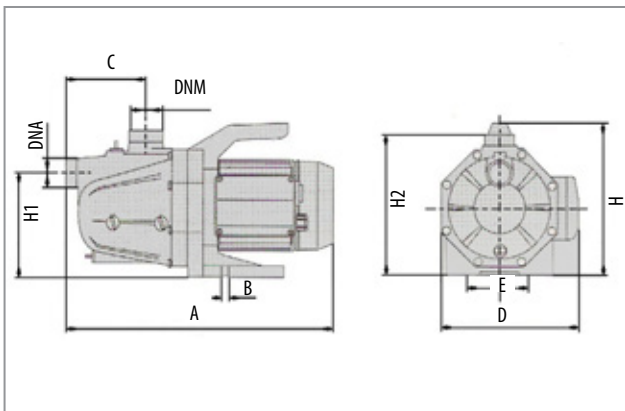

MODEL	A	B	C	D	E	H	H1	H2	DNA	DNM	Weight
ECOJET 130	15 3/4"	3/8"	4 5/8"	8 3/4"	5 3/4"	9 1/2"	6 1/2"	9 1/8"	1" NPT	1" NPT	23.4 lbs

MODEL	ELECTRICAL DATA				HYDRAULIC DATA		
	Voltage 60Hz	P1		In A	MAX Flow	Max Head	Max Pressure
		kW	Hp				
ECOJET 130	115v	1250	1	11.8	21 gpm	164 ft	71 psi