

# ECOVORT



## GENERAL DATA

### Applications

Multi-purpose submersible pumps for drainage, emptying, pumping water between containers, to circulate water in garden ponds, create water falls and play water features.

Suitable to pump clear water containing particles with maximum diameter up to 1"1/4.

- \* Drainage
- \* Emptying sumps
- \* Transferring water between large containers
- \* Circulating water in Garden ponds
- \* Water falls
- \* Fountains

### Constructional features of the pump

Technopolymer pump body.

Technopolymer impeller, diffuser, self-priming disc.

Anti-debris stainless steel strainer.

### Constructional features of the motor

Induction motor, closed and cooled with liquid being pumped

Wear resistant shaft with triple lip seals to ensure a long life.

Built-in thermic overload protection

Capacitor permanently in circuit.

Manufactured according to UL 778 -2010 & CSA 108-1

Motor protection: NEMA6P

Insulation class: F

Cable Length: 16ft

Standard voltage: 115v 60Hz

# TECHNICAL DATA

## MATERIALS

N°	PARTS*	MATERIALS
1	PUMP BODY	PP 30% GF NAT GRADE 6
2	TOP BODY	PP 30% GF NAT GRADE 5
3	PUMP BASE	PP 30% GF NAT GRADE 18
4	IMPELLER	NYLON
5	'O' RING	NBR 70
6	CABLE GLAND	NBR 70
7	ROTOR SHAFT	AISI 416 STAINLESS STEEL
8	CABLE	SJTOW
9	PRESSURE DISC	PP OMO 30
10	TRIPLE LIP SEAL	NBR 70
11	MOTOR CASING	CAST ALUMINUM
12	LOCK NUT	STAINLESS STEEL A2

\* In contact with liquid

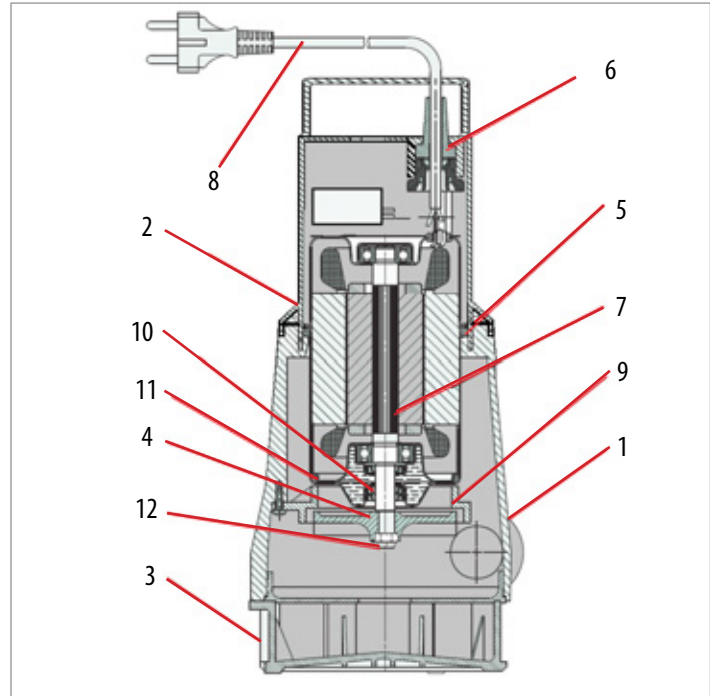

Operating Range:	From 1 to 60 gpm with a head up to 28ft (12 psi)
Liquid quality requirements:	clean, free from solids or abrasive substances, non viscous, non aggressive, non crystallized, chemically neutral, close to the characteristics of water
Liquid temperature Range:	From 32°F to 95°F
Maximum solids	1/2"
Maximum ambient temp.	104°F
Maximum operating pressure	12 psi
Maximum submersion	16 ft
Installation:	fixed or portable in a vertical position
Special version on request	other voltages and/or frequencies

# ECOVORT 510

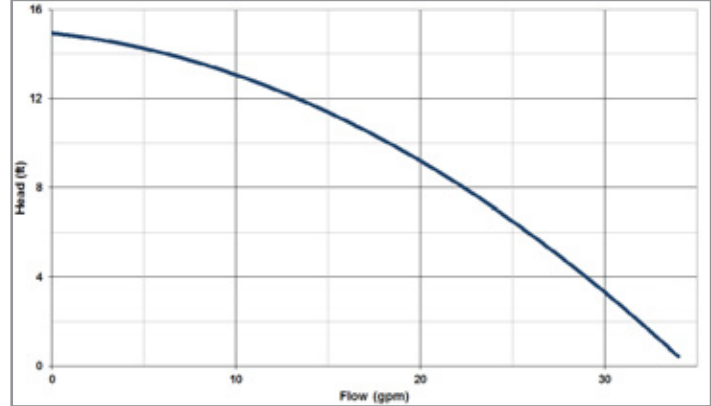
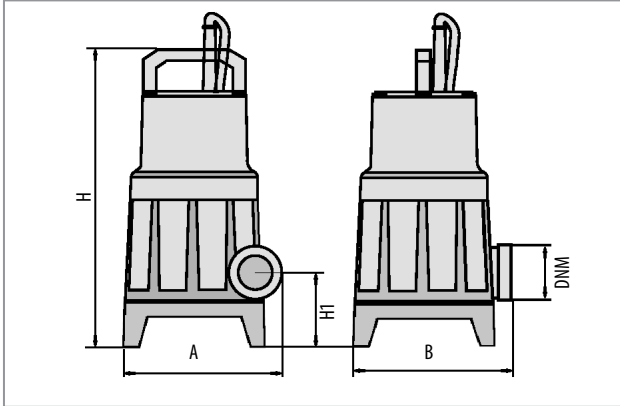

MODEL	A	B	H	H1	DNM	Weight
ECOVORT 510	5 1/2"	6 1/4"	13 1/8"	2 3/4"	1 1/4" NPT	8.0 lbs

MODEL	ELECTRICAL DATA				HYDRAULIC DATA		
	Voltage 60Hz	P1 Watt   Hp		In A	MAX Flow	Max Head	Max Pressure
ECOVORT 510	115v	330	1/3	3.0	34 gpm	15 ft	6 psi

# ECOVORT 510-A

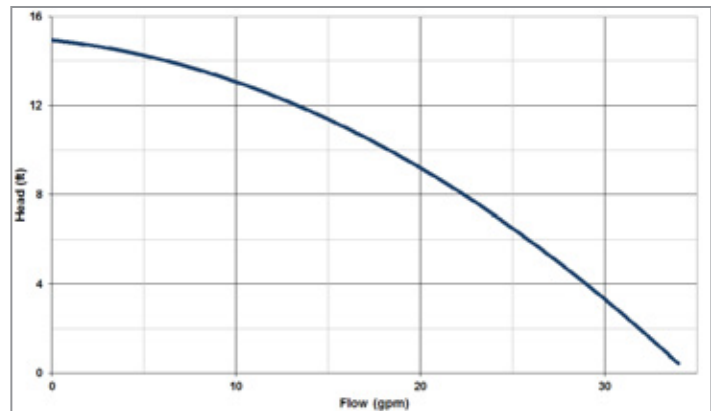
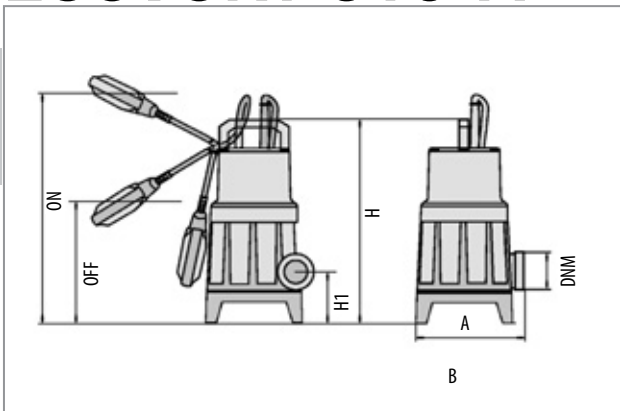

MODEL	A	B	H	H1	OFF	ON	DNM	Weight
ECOSUB 420	5 1/2"	6 1/4"	13 1/8"	2 3/4"	6 1/2"	15"	1 1/4" NPT	8.4 lbs

MODEL	ELECTRICAL DATA				HYDRAULIC DATA		
	Voltage 60Hz	P1 Watt   Hp		In A	MAX Flow	Max Head	Max Pressure
ECOVORT 510-A	115v	330	1/3	3.0	34 gpm	15 ft	6 psi

# ECOVORT 520

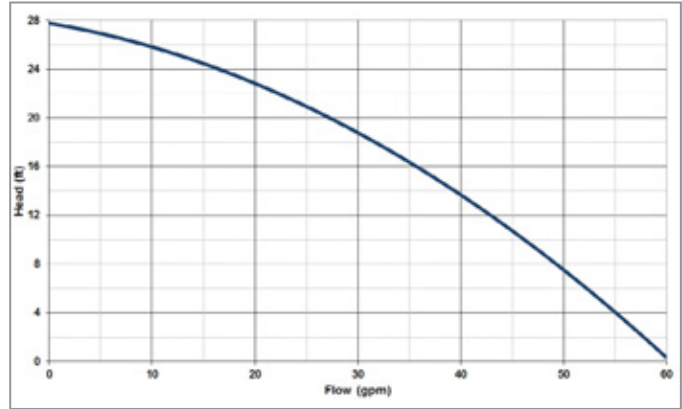
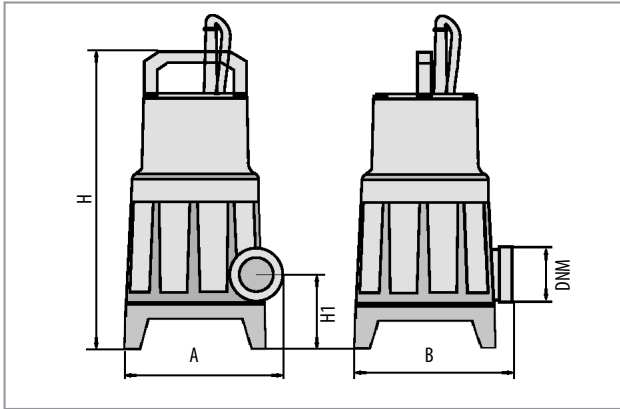

MODEL	A	B	H	H1	DNM	Weight
ECOVORT 520	5 1/2"	6 1/4"	13 1/8"	2 3/4"	1 1/4" NPT	11.5 lbs

MODEL	ELECTRICAL DATA				HYDRAULIC DATA		
	Voltage 60Hz	P1 kW   Hp		In A	MAX Flow	Max Head	Max Pressure
ECOVORT 520	115v	650	1/2	7.1	60 gpm	28 ft	12 psi

# ECOVORT 520-A

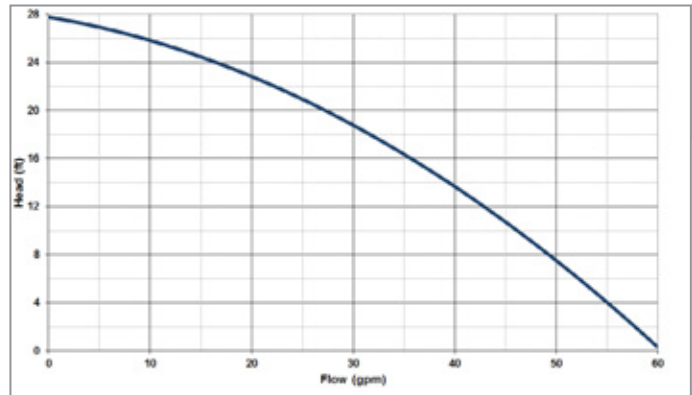
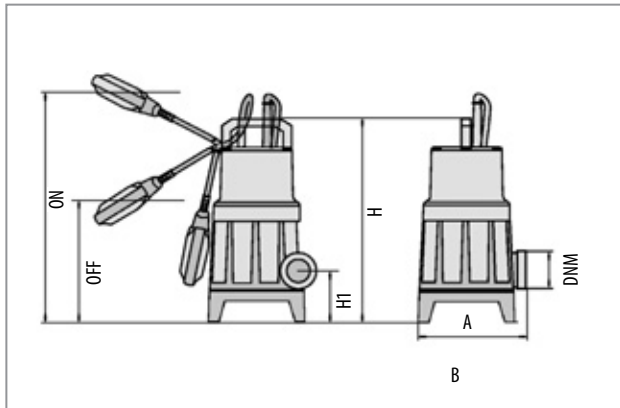

MODEL	A	B	H	H1	OFF	ON	DNM	Weight
ECOSUB 420	5 1/2"	6 1/4"	13 1/8"	2 3/4"	6 1/2"	15"	1 1/4" NPT	12.0 lbs

MODEL	ELECTRICAL DATA				HYDRAULIC DATA		
	Voltage 60Hz	P1 Watt   Hp		In A	MAX Flow	Max Head	Max Pressure
ECOVORT 520-A	115v	650	1/2	7.1	60 gpm	28 ft	12 psi